

EUROPEAN PATENT OFFICE

Patent Abstracts of Japan

PUBLICATION NUMBER : 59021533
PUBLICATION DATE : 03-02-84

APPLICATION DATE : 29-07-82
APPLICATION NUMBER : 57131290

APPLICANT : ASAHI GLASS CO LTD;

INVENTOR : TAKAHASHI SHIRO;

INT.CL. : C03B 19/04 C03B 17/00

TITLE : MANUFACTURE OF THIN GLASS CHIP

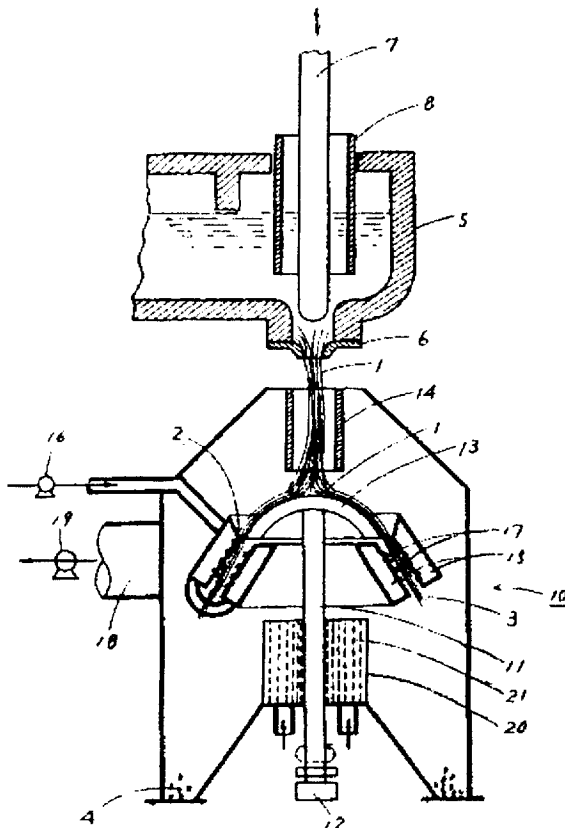

ABSTRACT : PURPOSE: To manufacture continuously thin glass chips in large quantities while easily regulating the thickness, etc. by diffusing molten glass fed continuously to the center of a horizontally rotating disk outward from the edge of the disk in the form of a thin film and by blowing air in the drawing direction of the thin film to harden and cut the thin film.

CONSTITUTION: When molten glass 1 is fed to the center of a rotating disk 13 from a feeding vessel 5 through an orifice ring 6, the glass 1 is diffused obliquely downward from the edge of the disk 13 in the form of a thin film by gravity and centrifugal force. The thin film 2 is floated by air blown from slits 17, and since the pressure of spouted air is applied to the moving direction of the film 2, the film 2 is made thinner by drawing. The film 2 is hardened by suitable cooling with the air, and at the same time, it is cut into thin chips 3. The chips 3 are light in weight, so they are sucked by a fan 19 and discharged from the apparatus through a suction pipe 18 together with a whirling rising flow of air passing through the slits 21 of a suction tube 20.

COPYRIGHT: (C)1984,JPO&Japio